



**FORD COYOTE FRONT SUMP PICK-UP
INSTALLATION INSTRUCTIONS
P/N 24576**

Parts List:



****Please note, this pickup only fits with Moroso oil pan P/N 20573. In order to install this pickup you must have the proper gasket / tray, Moroso P/N: 22936, or Ford P/N: BR3Z-6710 A. Modifications to the tray are required to use this pickup and are illustrated in the instructions. Additionally, if you have the old style 20573 pan, the slosh tray in the pan will have to be notched for clearance. See last page for a template.**

Completed installation

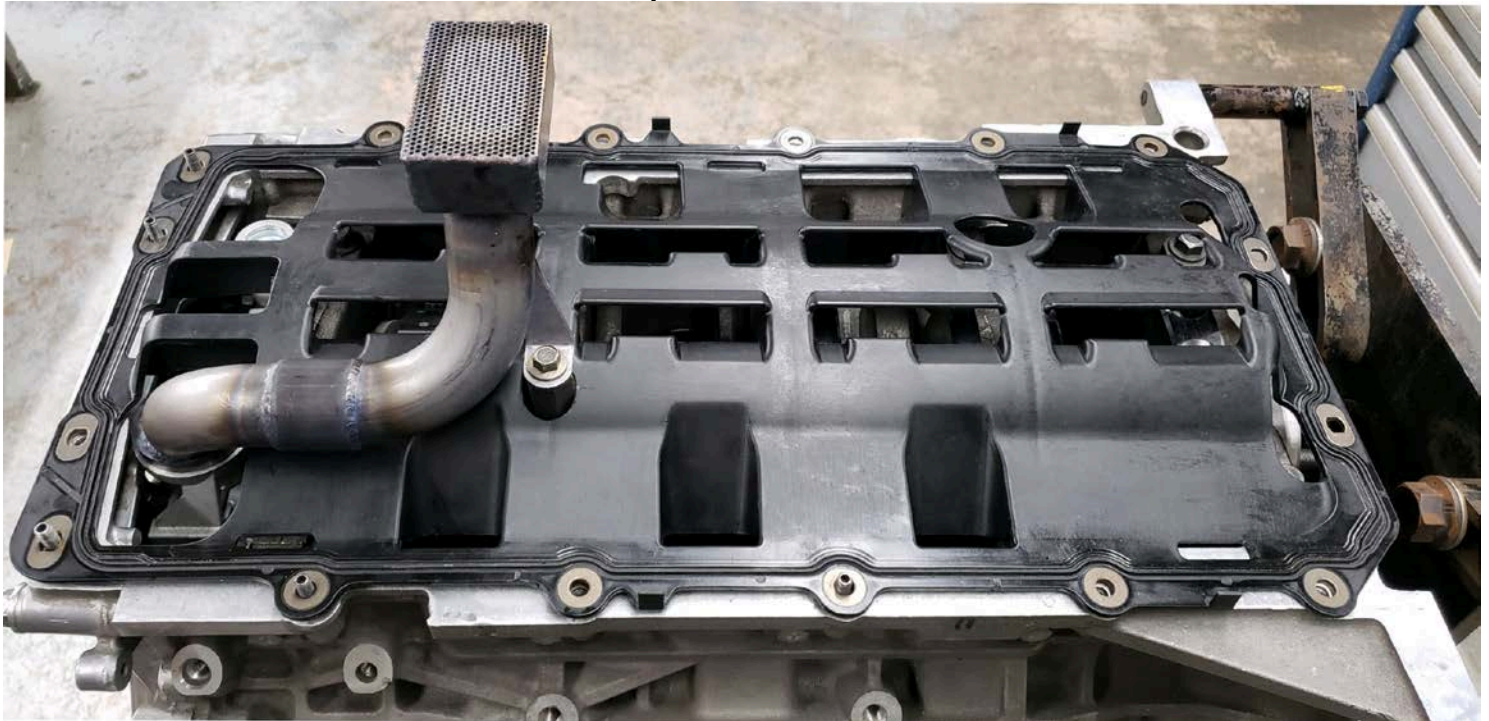

**For Technical Assistance, Call Moroso's Tech Line at
(203) 458-0542, 458-0546 8:30am – 5:00pm Eastern Time**

MOROSO PERFORMANCE PRODUCTS, INC
80 CARTER DR • GUILFORD, CT 06437-2116
Phone: (203) 453-6571 • Fax: (203) 453-6906

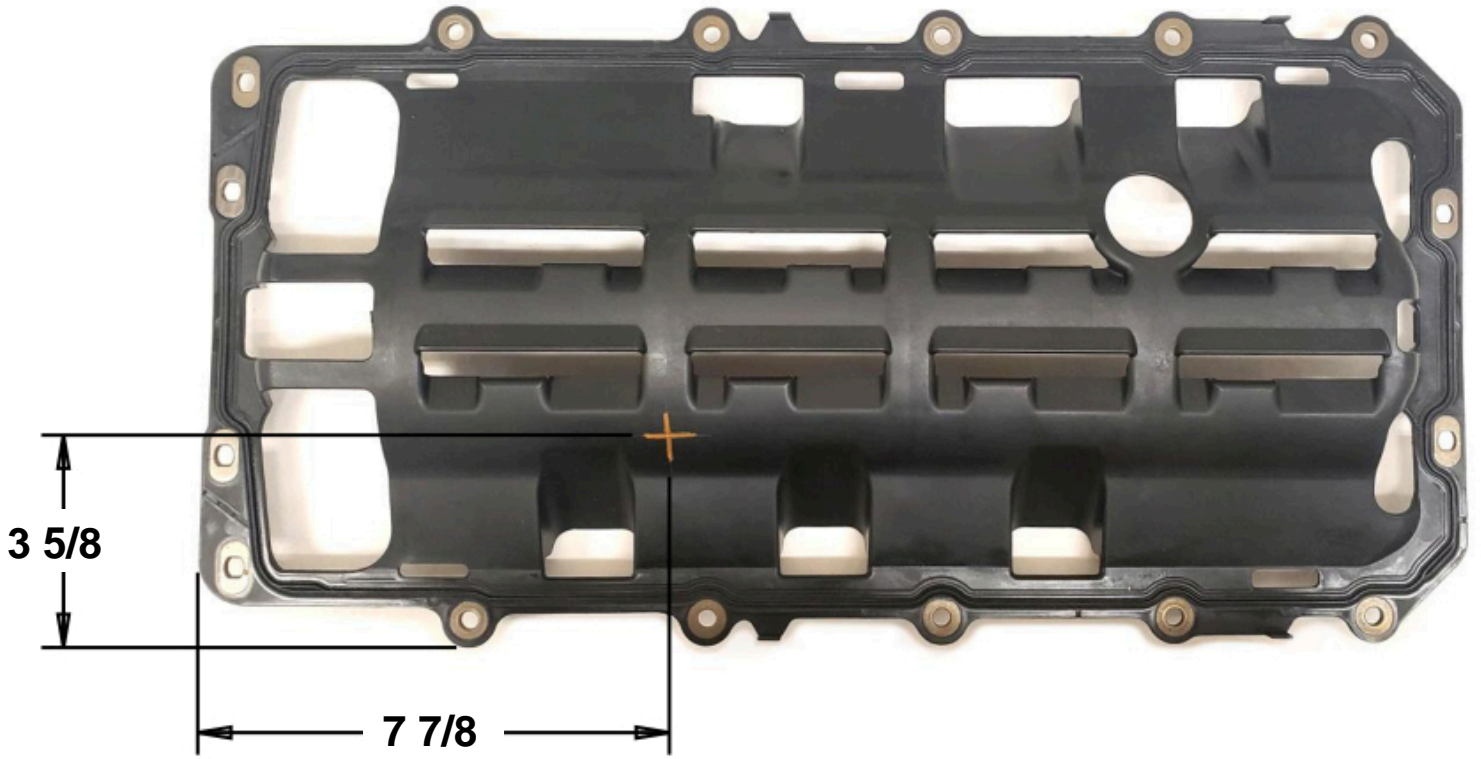

Step 1: Scribe the tray in the location shown above.

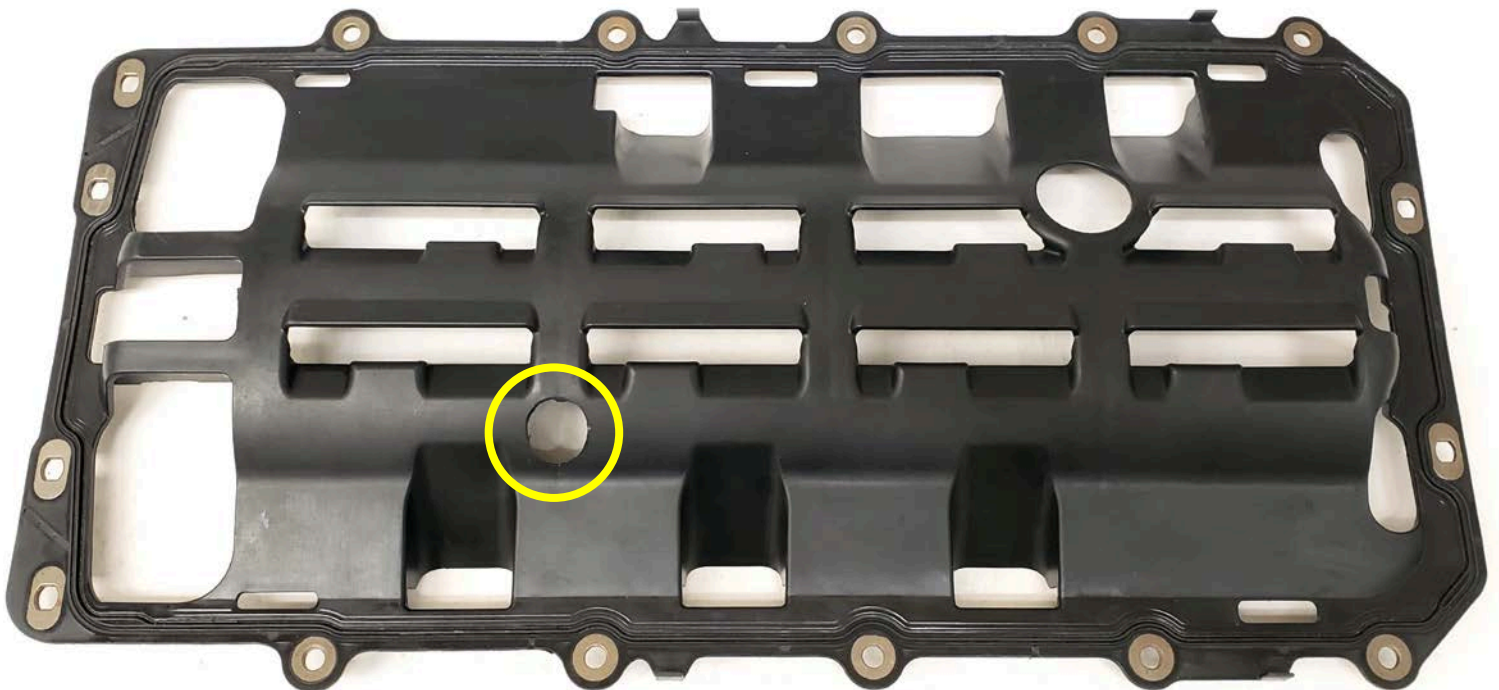

Step 2: Drill a hole in the scribed location using a $\frac{7}{8}$ " hole saw.

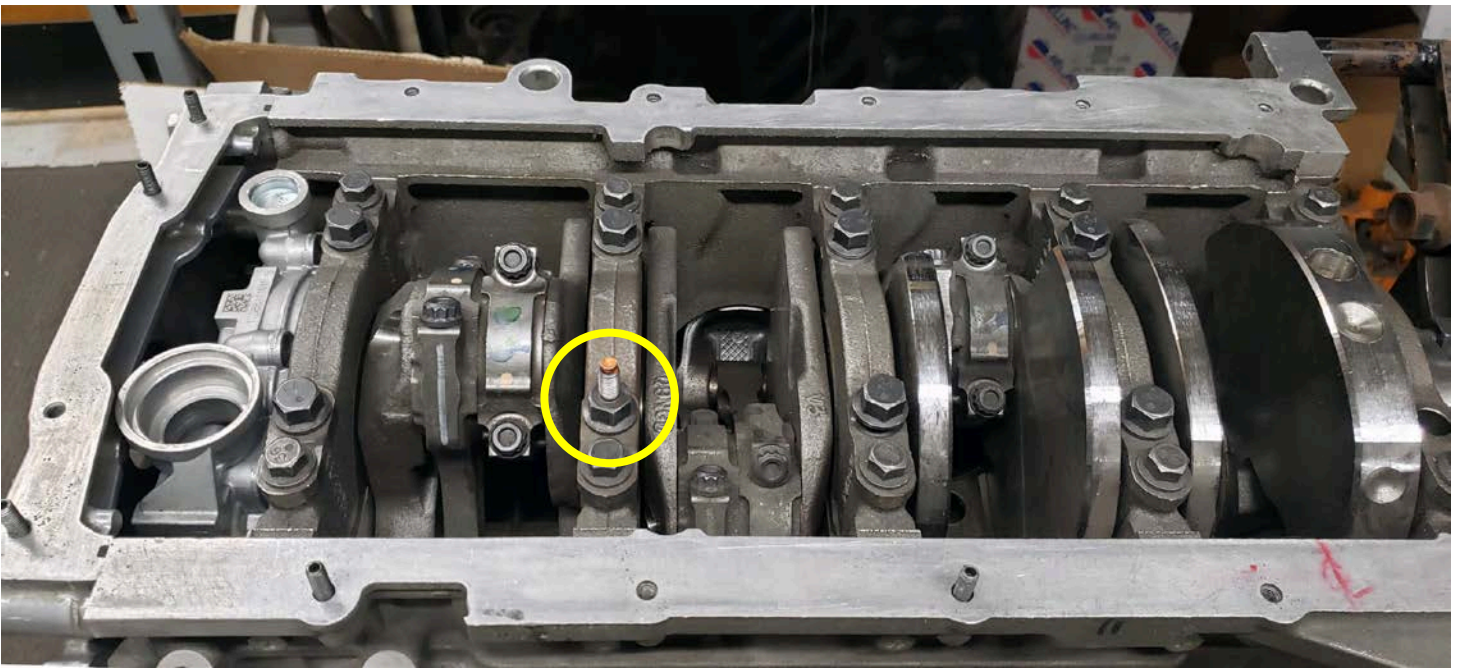

Step 3: Remove the factory main cap bolt and install the provided main cap bolt in the location shown above. Tighten the main cap bolt to factory specifications.

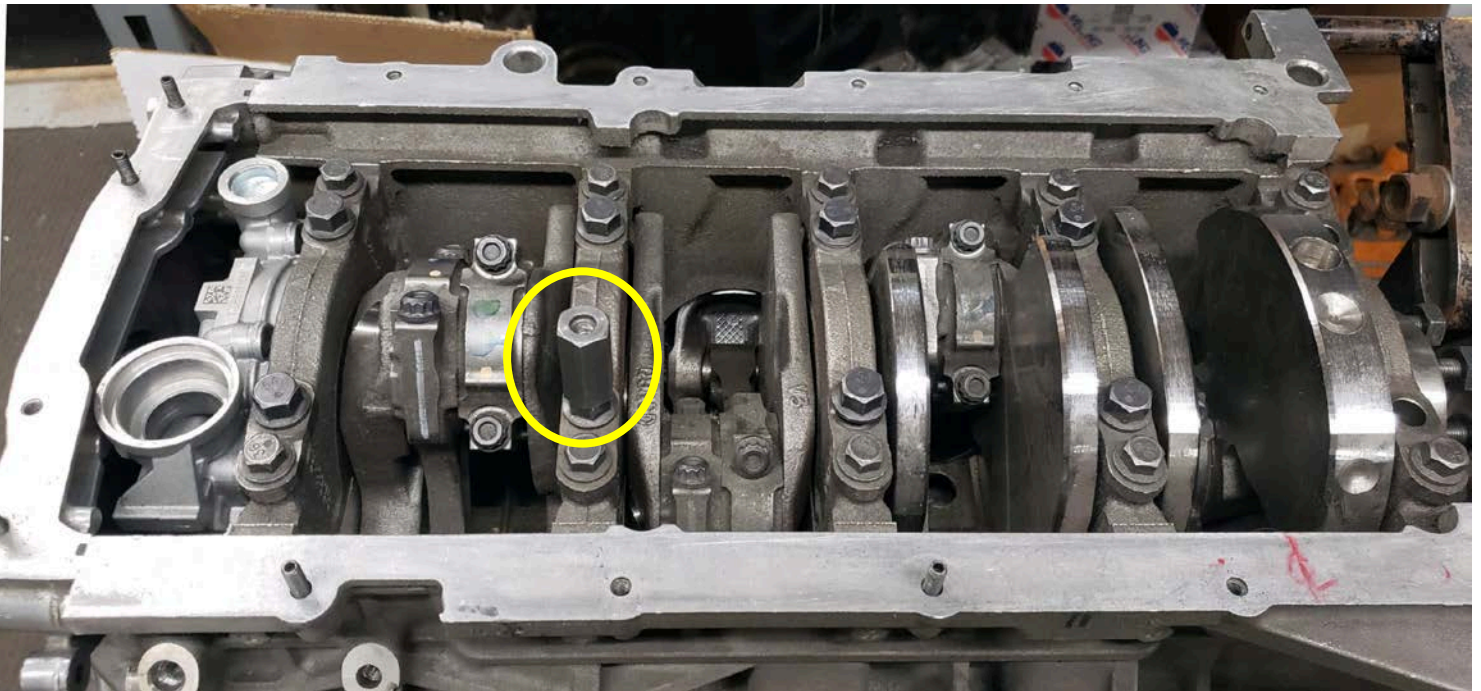

Step 4: Install and torque the standoff to 20 ft.-lbs.



Step 5: Install the provided O-ring on the pickup and lubricate with engine oil before continuing.



Step 6: Install the tray on the studs, and then lift the front of the tray while simultaneously inserting the pickup into the pump.



Step 7: Note: pickup must be fully seated in the oil pump.

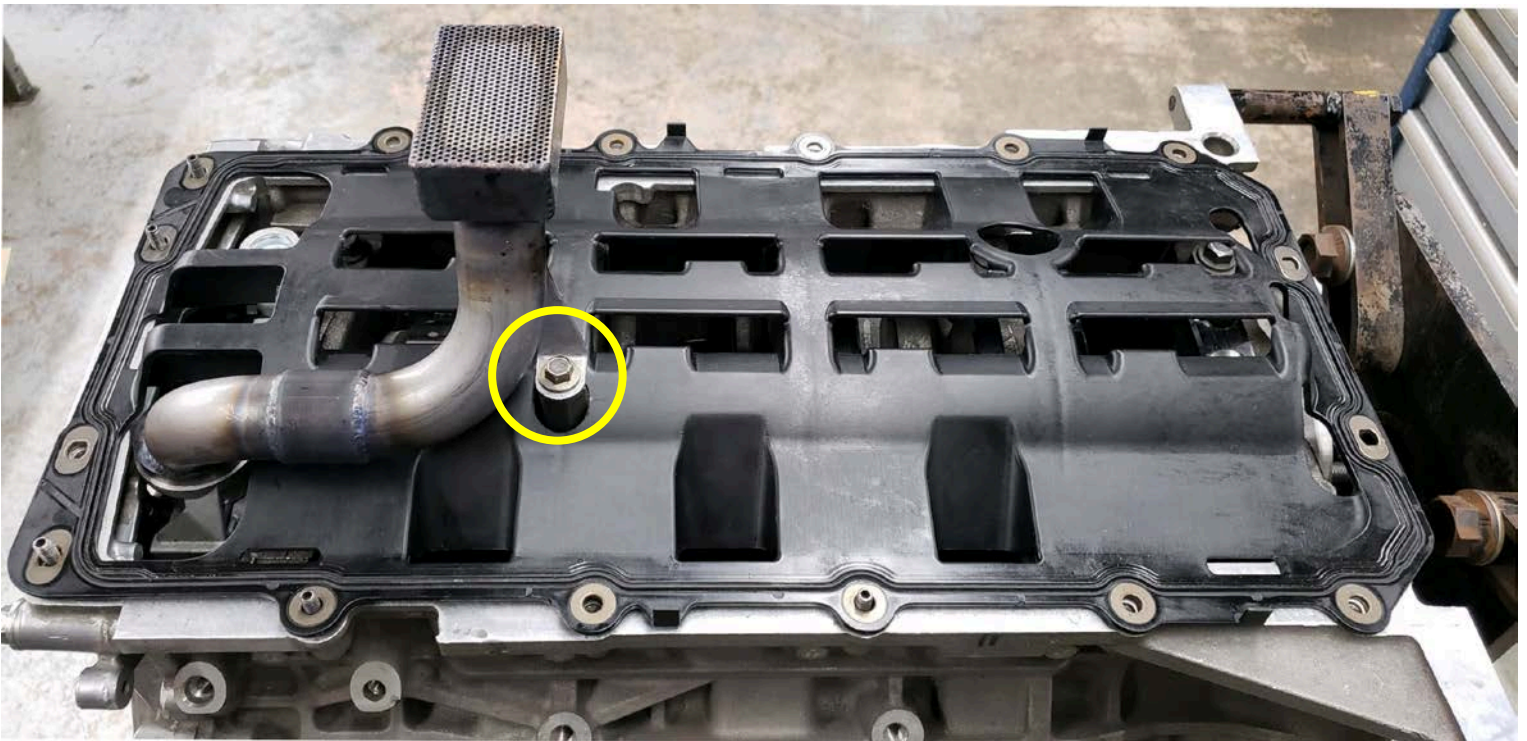

Step 8: Fasten the pickup bracket to the standoff using the provided 8mm flange head screw. Torque to 20 ft.-lbs.

IMPORTANT: If you have an old style Moroso oil pan tray, you must notch the tray using the template below. Failure to do so will cause interference between the pickup tube and the tray, not allowing the pan to seal properly.

