



**INSTALLATION INSTRUCTIONS**  
**P/N: C3028**  
**UNIVERSAL BOLT-ON DRIVESHAFT LOOP**

This unit is designed to prevent the driveshaft from contacting the racing surface in the event of universal joint failure. The 360° design is required by all major racing organizations. Follow your racing organization's guidelines for correct positioning of the loop.

**PARTS LIST**

2) 180° Loop	2) 90° Brackets
8) 3/8"-16 x 1" Hex Bolts	8) Lock Washers
8) 3/8"-16 Nuts	8) 3/8" Washers

**INSTALLATION**

1. Determine the location of the loop on the floor pan.
2. Assemble the loop according to the diagram. Install all bolts so that the bolt heads face the driveshaft. Do not install the upper 180° loop at this time.
3. Position the assembly under the vehicle, making sure that it is centered with the driveshaft.
4. Mark the positions of the mounting holes on the floor pan.
5. Drill the mounting holes through the floor pan using a 13/32" drill bit.
6. Install the upper 180° loop onto the assembly at this time.
7. Remove the driveshaft from the vehicle.
8. Install the loop assembly using 3/8" bolts. We recommend using large diameter washers on the opposite side of the floor pan to disperse the load.
9. Re-install the driveshaft into the transmission tailshaft. Move the driveshaft up and down to check for interference. Re-adjust the loops to eliminate interference.
10. Tighten all bolts at this time.

*For Technical Assistance, call Competition Engineering's Tech Line at  
(203) 458-0542, 8:30am-5:00pm Eastern Time*

**COMPETITION ENGINEERING**

80 Carter Drive • Guilford, CT 06437

Phone: (203) 453-5200 • Fax: (203) 453-6906

Rev. C  
082014

**Visit Us At [www.competitionengineering.com](http://www.competitionengineering.com)**

C3028INST

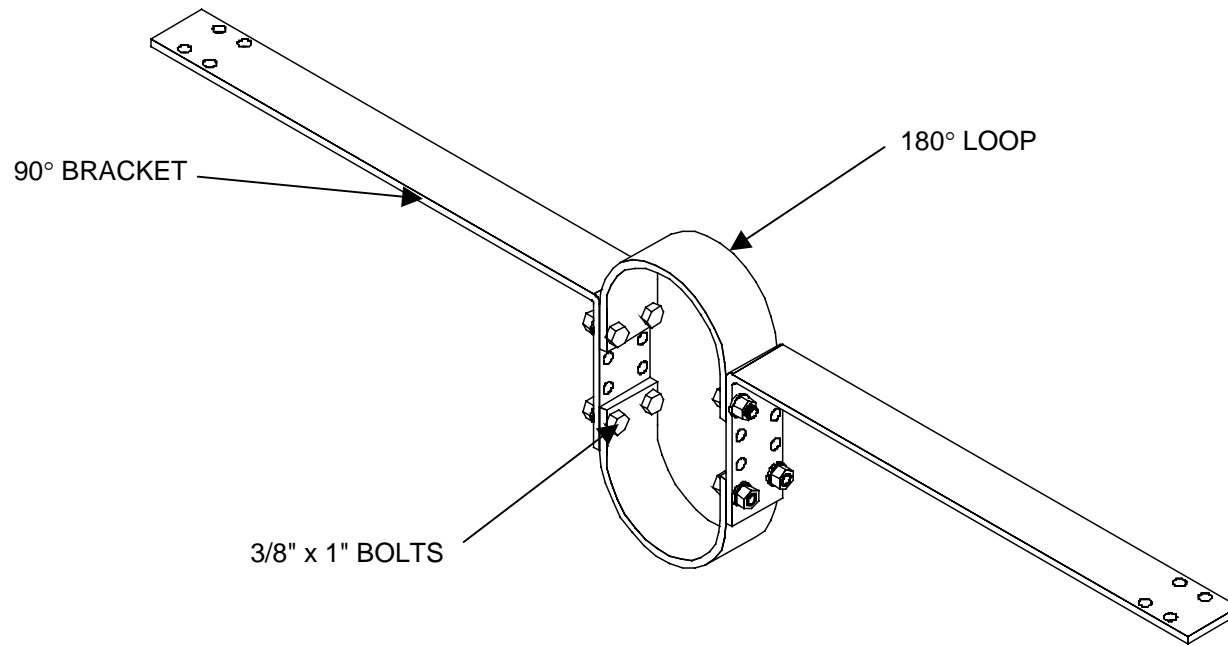

## ASSEMBLY DIAGRAM