



COMPETITION ENGINEERING "BOLT-ON" WHEEL-E-BAR KIT
P/N C2043

ITEM	DESCRIPTION	QUANTITY
A	LOWER STRUT ASSEMBLY	2
B	UPPER STRUT ASSEMBLY	2
C	REAR HOUSING BRACKET	2
D	AXLE	1
E	WHEEL	2
F	SADDLE BRACKET	2
G	CLEVIS	2
H	1/2-20 JAM NUT	2
I	PIT PIN	2
J	1/2-20 NYLON INSERT LOCK NUT	4
K	3/8-24 X 2 3/4 LONG HEX HEAD BOLT	2
M	3/8-24 X 1 1/2 LONG HEX HEAD BOLT	4
N	3/8-24 NYLON INSERT LOCK NUT	2
O	SHORT ALUMINUM STRUT	2
P	5/16-24 X 1 1/2 LONG HEX HEAD BOLT	2
Q	5/16-24 NYLON INSERT LOCK NUT	2
R	SPRING (COIL)	2
S	THREADED COLLAR	2
T	SPRING ADJUSTER	2

IMPORTANT

State and local ordinances may prohibit the Bolt-on Wheel-E-Bars from extending beyond the rear bumper. If this situation exists and you wish to shorten the Wheel-E-Bars, the upper and lower struts can each be shortened and redrilled.

INSTALLATION ON REAR AXLE HOUSING

With car on level surface, locate Bolt-on Wheel-E-Bar under the car with the brackets up against the housing and prop up the Wheel-E-Bar wheels to a height of about 6" off the ground for street use (3 1/2" for strip use). In this position, fasten the Housing Saddle Brackets (F) over the rear end housing and attach to Rear Housing Brackets (C) using the 1/2-20 Nylocks provided.

IMPORTANT

1. Care must be taken to insure that the Bolt-on Wheel-E-Bars will clear driveways, etc., without being severely loaded. If the bars are to be used for *street* use, it is recommended that they be loosely bolted to the housing while backing out of and pulling into a driveway (for example) until the bars "adjust" to the required height. Once this height is determined, the bars can be secured to the housing. Maximum torque for the Rear Housing Bracket Nuts is 55 ft. lbs.
2. If the Rear Housing Brackets are too big for your particular housing so that they cannot be bolted securely, the Housing Bracket Saddle (part F) can be welded to the housing and the Rear Housing Bracket (C) bolted to it, thereby allowing the Wheel-E-Bars to be removed.
3. Natural Rubber Wheels Available – If you desire to replace the standard synthetic rubber wheels with our finest wheels of natural rubber and featuring an aluminum hub with ball bearing sleeve, you can do so. The rubber wheels are the same as used on our Professional Competition Wheel-E-Bars and are plenty durable for both street and strip use. Just order P/N C7058 for the natural rubber wheels.

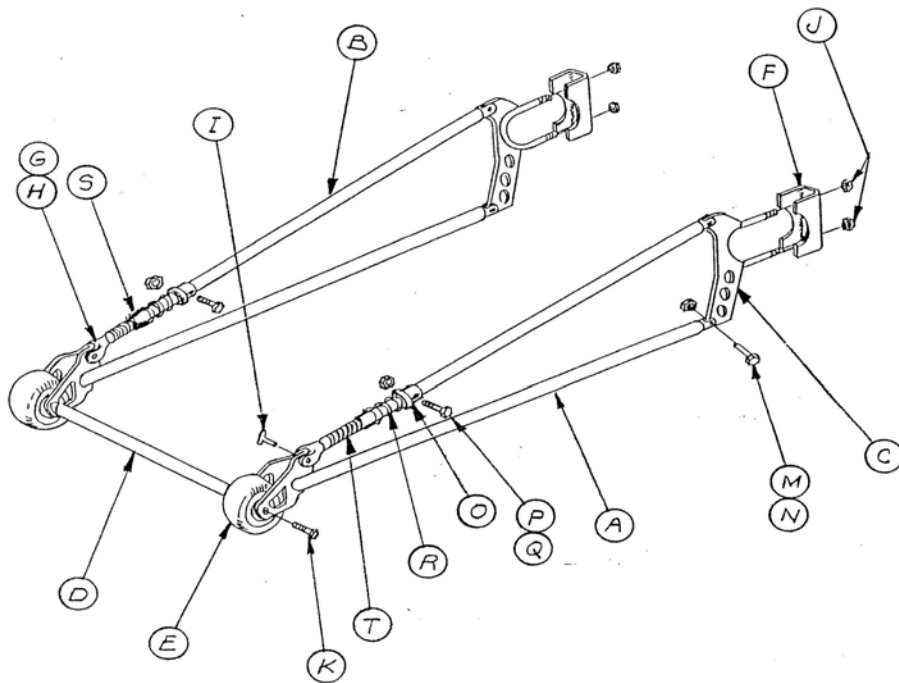

*For Technical Assistance, call Competition Engineering's Tech Line at
(203) 458-0542, 8:30am-5:00pm Eastern Time*

COMPETITION ENGINEERING

80 Carter Drive • Guilford, CT 06437

PHONE: (203) 453-5200 • Fax: (203) 453-6906

REV. B
032211

Visit Us At www.competitionengineering.com

C2043INST