

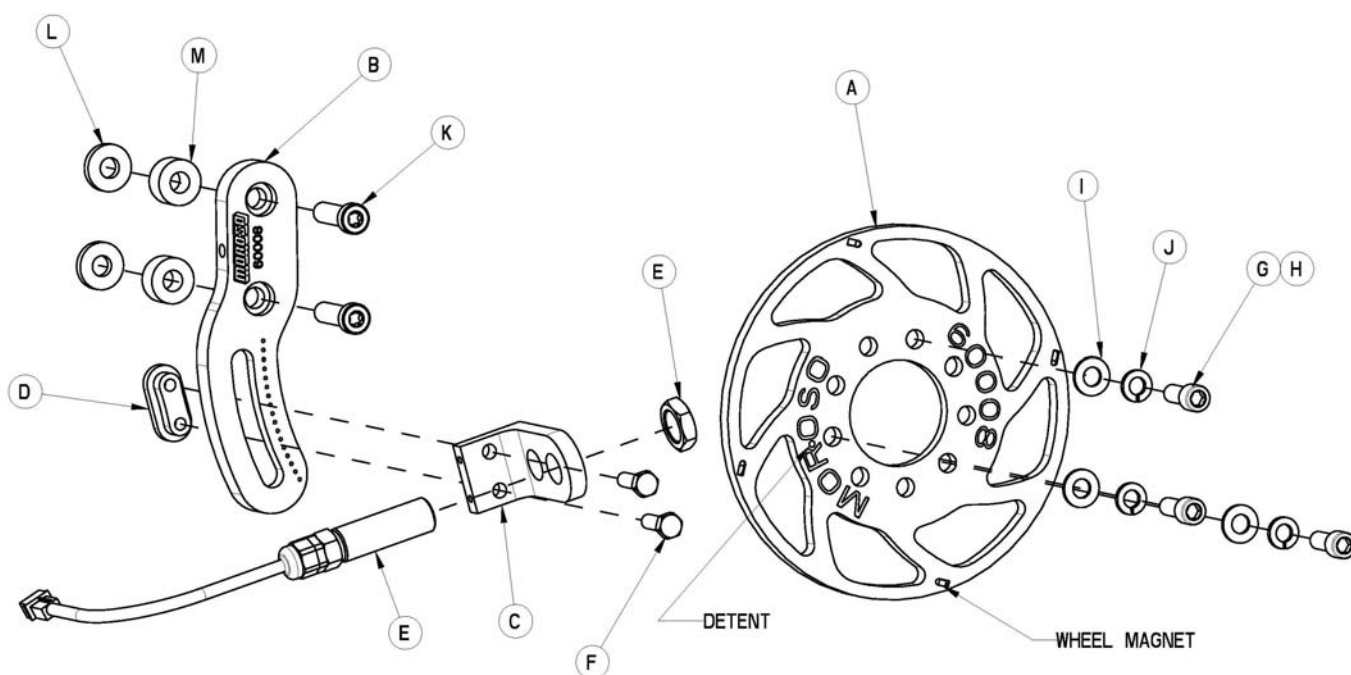

INSTALLATION INSTRUCTIONS

P/N: 60008, BBC ULTRA-SERIES CRANK TRIGGER

This crank trigger kit has been specifically made to fit a Big Block Chevrolet with a minimum diameter crank hub or damper of 7-1/4". It will only mount to the right side of the motor. If your application is for an engine other than Big Block Chevrolet, please refer to the MOROSO catalog. Crank Triggers are not legal for sale or use on pollution-controlled vehicles.



PARTS LIST

ITEM	DESC	QTY	ITEM	DESC	QTY
A	Wheel	1	I	3/8 Washer	3
B	Arm	1	J	3/8 Lock Washer	3
C	Bracket	1	K	7/16-14 X 1-1/2 Low Head	2
D	Slot Block	1	L	7/16 Washer	4
E	Sensor W/ Jam Nut	1	M	Spacer	6
F	5/16-18 X 1 Hex Head	2	N	Plug Connector (not shown)	1
G	3/8-16 X 1 Socket Head	3	O	Socket Contacts (not shown)	2
H	3/8-24 X 1 Socket Head	3			

NOTE: When mounting any of the specified hardware, MOROSO recommends that they be installed with some type of thread locker such as LOCTITE®242. This will aid in maintaining the integrity of the assembly during its exposure to the intense high frequency vibrations of racing. The recommended tightening torque values are as follows: 5/16 hardware - 20 ft-lbs; 3/8 hardware - 30 ft-lbs; 7/16 hardware - 40 ft-lbs.

INITIAL TIMING

Set your engine to the desired timing by turning the engine over until the #1 cylinder is under compression and the desired timing mark on your damper or crank hub is lined up with the TDC pointer (Example: 30° BTDC). This will be the timing that your crank trigger will be initially set to. Do not change this setting until the Crank Trigger is completely installed.

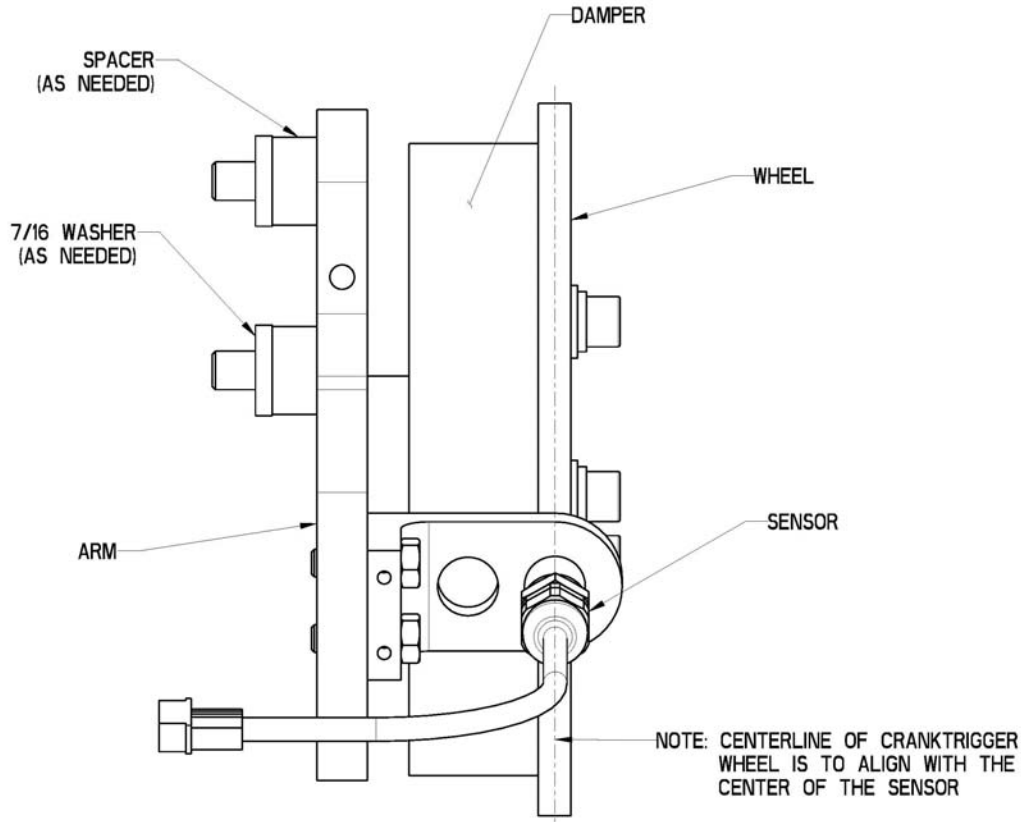

PRE-MOUNTING OF CRANK TRIGGER

1. Set distributor so that the rotor is pointed to the desired position for the cap and the number 1 cylinder. Tighten the distributor hold down.
2. Install the Sensor into the appropriate hole of the Bracket until it sticks out $\frac{3}{4}$ " and install jam nut leaving it loose.
3. Using the 5/16 Hex Head fasteners and the Slot Block, install the Bracket onto the Arm and leave it loose.
4. If using a MOROSO Crank Trigger Adjuster part number 60025, install it now. It can be purchased and installed on the engine while in most vehicles at a later time.
5. Install the Crank Trigger Wheel onto the damper or crank hub. Be sure it is seated correctly on the receiver and hold it in place with one or two of the appropriate Socket Head fasteners.
6. Mount the Arm onto the engine using the necessary 7/16 Washers and Spacers that will center the Wheel and Sensor. Tighten the Low Head fasteners until they are snug.
7. Move the Sensor through its travel on the arm and confirm that the Sensor maintains its distance from the Wheel. If it does not, loosen the Arm from the engine and adjust it accordingly. When set correctly, completely tighten the Arm to the engine.

WHEEL & SENSOR POSITION

1. Both the Arm and the Wheel have detents in them as a visual aid (see the exploded parts view on page 1 for the wheel detent location). The arm has a pattern of detents in it that are 2° apart. These are a visual guide to aid you in the setup and adjustment of the crank trigger. The marks can be read on either edge of the Bracket. The crank trigger wheel has one hole that is marked with a detent and is located between the R and O in the MOROSO name. This hole will be used as a starting point in the wheel positioning process.
2. Snug Sensor Bracket so it is centered in its travel on the Arm.
3. Remove Socket Head fasteners from wheel, but keep the wheel correctly seated on the damper (or hub).
4. Align the marked hole on the wheel with the tapped hole on the damper (or hub) that is closest to the sensor. Using this balancer hole, rotate the wheel from hole to hole until you find the position in which one of the four magnets is closest to the center of the arm slot.
5. Install and completely tighten the appropriate 3/8 Socket Head fasteners and Lock Washers. If installing a damper (or hub) mounted drive mandrel or pulley, assure the wheel remains in the optimal position you established. See the MOROSO catalog for pulleys, adapters and drive mandrels for this application.
6. Move the sensor so it is directly in front of the Wheel Magnet and tighten the Hex Head fasteners completely.
7. Set the gap between the end of the sensor and the wheel to .040”-.060” and completely tighten the sensor’s jam nut.

DISTRIBUTORS

This crank trigger requires the use of a distributor that is either designed specifically for crank triggers or one that has a fixed advance. Distributors that have a vacuum and/or mechanical advance can be used, but they must be locked out. This can be done by removing the unnecessary components and by either welding (preferred) or bolting the advance so that the rotor is fixed rotationally to the shaft. See the MOROSO catalog or call for Crank Trigger Distributor applications.

WIRING

All electrical power should be turned off prior to wiring the Sensor into the ignition system. A mating connector and contacts have been included and can be terminated to the wires of most ignition systems. The connector supplied on the Sensor is labeled with a “1” and a “2”. The color of the sensor wires can be seen at the back of the connector. Side “1” is a green wire which is negative (-). Side “2” is a purple wire which is positive (+). This polarity must be maintained when connecting the Sensor to the ignition box wiring. Refer to ignition box manufacturers instructions and wiring diagram. The wires from the Sensor to the ignition box must be routed correctly to prevent EMI from distorting the signal. The wires should be routed near the frame or engine. They should not be near any of the spark plug wires, coil wire(s) or coil, alternator wire and any ignition system wires. Do not pass the wires through the same hole in the firewall as any other wire(s). The wires shall be kept away from areas of extreme heat and fluid or debris contamination.

ENGINE CHECK AND TIMING ADJUSTMENT

1. Start engine and run it at an idle speed. Check timing as normal using a timing light on the pointer and balancer. Even if the timing is off proceed to step 2.
2. Aim the timing light at the sensor and spinning crank trigger wheel. If a Wheel Magnet is not showing directly in front of the sensor shut off the engine and disconnect the electrical power. Check the wiring from the sensor to the ignition box.
3. If needed, loosen the sensor bracket and move the sensor to achieve the desired engine timing.
Caution should always be exercised when working on/or around the front of a running engine.
4. Tighten the bolts, recheck the timing, shut off engine and check gap between the sensor and the wheel.

ROTOR PHASING

The rotor tip phasing must be checked and optimized for proper ignition system performance and longevity. Since the rotor tip position relative to the cylinder post will be the same for all eight cylinders, it is only necessary to check it only on one.

1. Modify an old distributor cap by making a hole (or opening) in it that will allow you to see a cylinder terminal and the rotor tip as it passes by. You can perform the check on any cylinder, so choose one that will allow you to easily view it.
2. Install the modified cap and ignition wires and start the engine.

WARNING: Exercise caution around the hole when the engine is running. Do not let anything near and/or into the cap. A catastrophic event, damage to the distributor, personal injury and/or electrocution can occur.

3. Aim a timing light into the hole in the cap and view the rotor tip's position relative to the cylinder terminal. The timing light pickup can be either clamped onto the ignition wire that corresponds to the cap hole or to the coil wire.
4. The rotor tip should be centered on the cylinder terminal. For situations where the timing is retarded during usage, the trailing edge of rotor tip must be towards or aligned with the trailing edge of the cylinder terminal.
5. If needed, loosen the distributor hold down and adjust it so the rotor tip is phased correctly. Since the rotor is fixed rotationally to the shaft and the crank trigger is controlling your timing, the engine's timing will not change.
6. Remove modified cap and replace it with the cap that will be run on the engine. The modified cap cannot be run on the engine at any other time except when checking the rotor tip phasing.

**For Technical Assistance, Call Moroso's Tech Line at
(203) 458-0542, 458-0546 8:30am – 5:00pm Eastern Time**

MOROSO PERFORMANCE PRODUCTS, INC
80 CARTER DR • GUILFORD, CT 06437-2116
Phone: (203) 453-6571 • Fax: (203) 453-6906

Visit Us At www.moroso.com