



## ROLLER PILOT BEARING P/N 41100 INSTALLATION INSTRUCTION

**Fits:** All Chevrolet V8, V6 and Buick V6 Engines.

No modifications to crankshaft or input shaft are required.

1. Remove old pilot bushing and press roller bearing into crankshaft using an arbor press and 1" o.d. pilot punch. Place the flat side of the bearing towards front of the crankshaft. Do NOT use a hammer! Do NOT wipe or wash out the high temperature lubricant!
2. For the roller bearing and transmission to work properly, they must be perfectly aligned with the crankshaft. Check the bell housing bore and transmission face with a dial indicator. Tolerances are shown below.

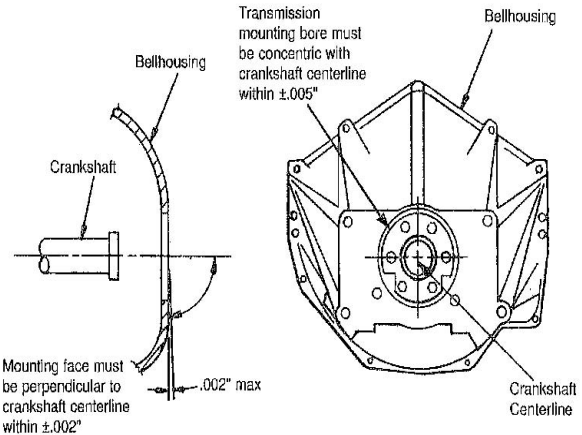

---

**For Technical Assistance, Call Moroso's Tech Line at  
(203) 458-0542, 458-0546 8:30am – 5:00pm Eastern Time**

**MOROSO PERFORMANCE PRODUCTS, INC**  
80 CARTER DR • GUILFORD, CT 06437  
Phone: (203) 453-6571 • Fax: (203) 453-6906

**Visit Us At [www.moroso.com](http://www.moroso.com)**